

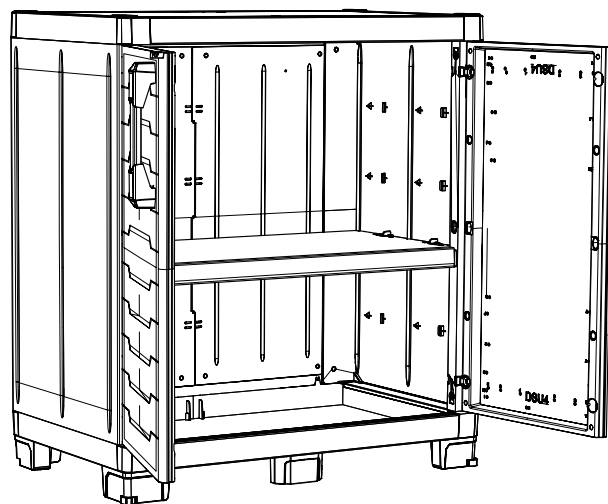

XL GARAGE - BASE

EN ASSEMBLY INSTRUCTIONS FR INSTRUCTIONS DE MONTAGE DE MONTAGEANLEITUNG NL MONTAGEVOORSCHRIFT
ES INSTRUCCIONES DE MONTAJE IT ISTRUZIONI DI MONTAGGIO PT INSTRUÇÕES DE MONTAGEM EL ΟΔΗΓΙΕΣ ΣΥΝΑΡΜΟΛΟΓΗΣΗΣ
PL INSTRUKCJA MONTAŻU ZH 装配说明 HU ÖSSZESZERELÉSI ÚTMUTATÓ HR UPUTE ZA MONTAŽU RO INSTRUȚIUNI DE ASAMBLARE
SL NAVODILA ZA MONTAŽO BG ИНСТРУКЦИЯ ЗА МОНТАЖ RU ИНСТРУКЦИЯ ПО МОНТАЖУ UK ІНСТРУКЦІЯ З МОНТАЖУ
CZ NÁVOD K MONTÁŽI SK MONTÁŽNE POKYNY LT MONTAVIMO INSTRUKCIJA LV UZSTĀDĪŠANAS INSTRUKCIJA ET PAIGALDAMISE JUHEND

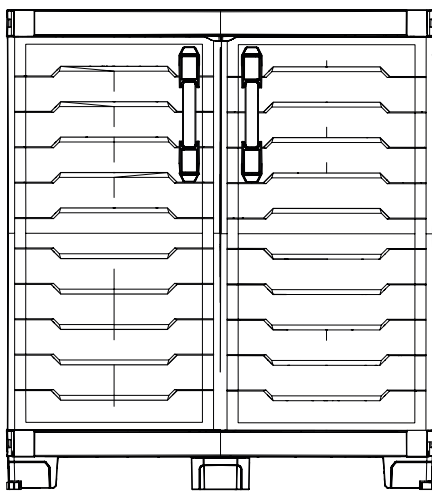







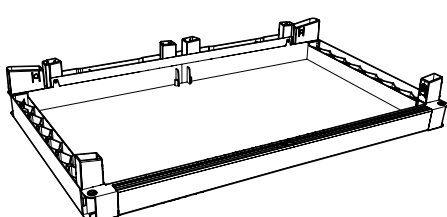
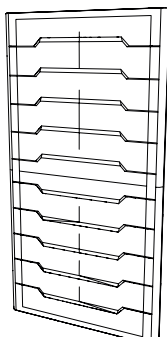
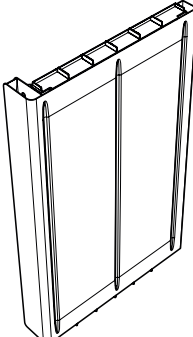
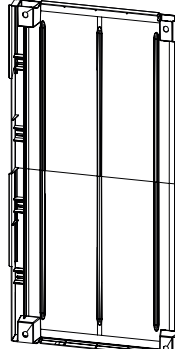
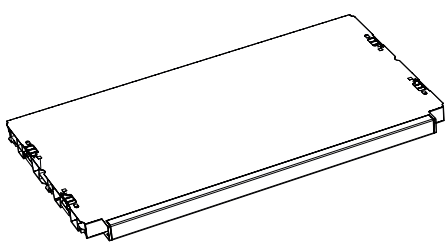
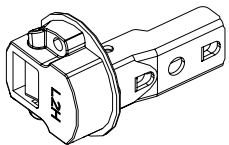
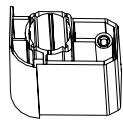
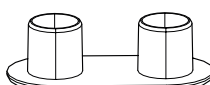
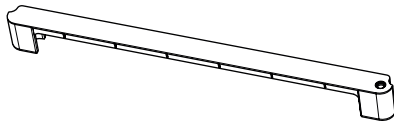

Keter Italia

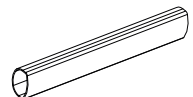
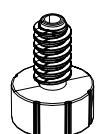
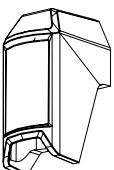
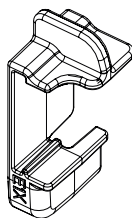
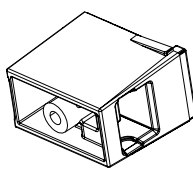
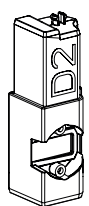
Via Ing. Taliercio 2, 31024 Ormelle TV
Tel: +39 0422 745900, Fax +39 0422 745929

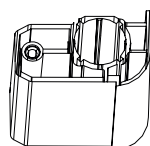
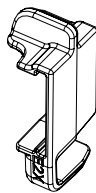
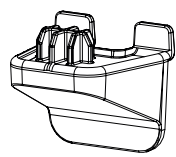
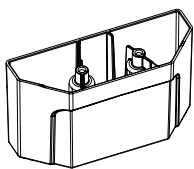
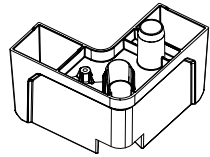
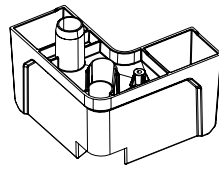
WWW.KETER.COM

ASSEMBLY PARTS | PIÈCES À ASSEMBLER | PIEZAS DE ENSAMBLE | MONTAGETEILE | MONTAGESTUKKEN | PARTI DA MONTARE | PEÇAS DE MONTAGEM | ΑΝΤΑΛΛΑΚΤΙΚΑ ΣΥΝΕΛΕΥΣΗ CZEŚCI PRZEZNACZONE DO MONTAŻU | 装配零件 | ÖSSZESZERELENDŐ RÉSZEK | DIJELOVI ZA MONTAŽU | COMPONENTE DE ASAMBLAT | DELI, KI JIH JE TREBA SESTAVITI | ЧАСТИ, КОИТО ТРЯБВА ДА БЪДАТ СГЛОБЕНИ | ЧАСТИ, ПОДЛЕЖАЩИЕ УСТАНОВКЕ | ЧАСТИНИ, ЩО ПІДЛЯГАЮТЬ СКЛАДАННЮ | ČÁSTI URČENÉ K MONTÁŽI | SÚČASTI, KTORÉ SA MAJÚ MONTOVAŤ | MONTUOJAMOS DALYS | DETALĀS MONTĀŽAI | KOKKUPANDAVAD OSAD

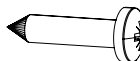
 XBT x2		 DSU4 x2		 XPL x2		 XB x2	
 XRA x1		 L2H x4		 XCD x4		 x4	
 XCDD/XCLD x1		 XCDS/XCLS x1		 x2		 x2	
 4x	 E1X x2	 B6 x4	 D2 x2	 D1 x2	 XCS x4		
 E2X x2	 E3X x1	 XFC x2	 XFD x2	 XFS x2			
 Y1 (x8) 3.9x16		 XCDD/XCLD x1		 XCDS/XCLS x1			
 Y2 (x16) 4.5x25							

1

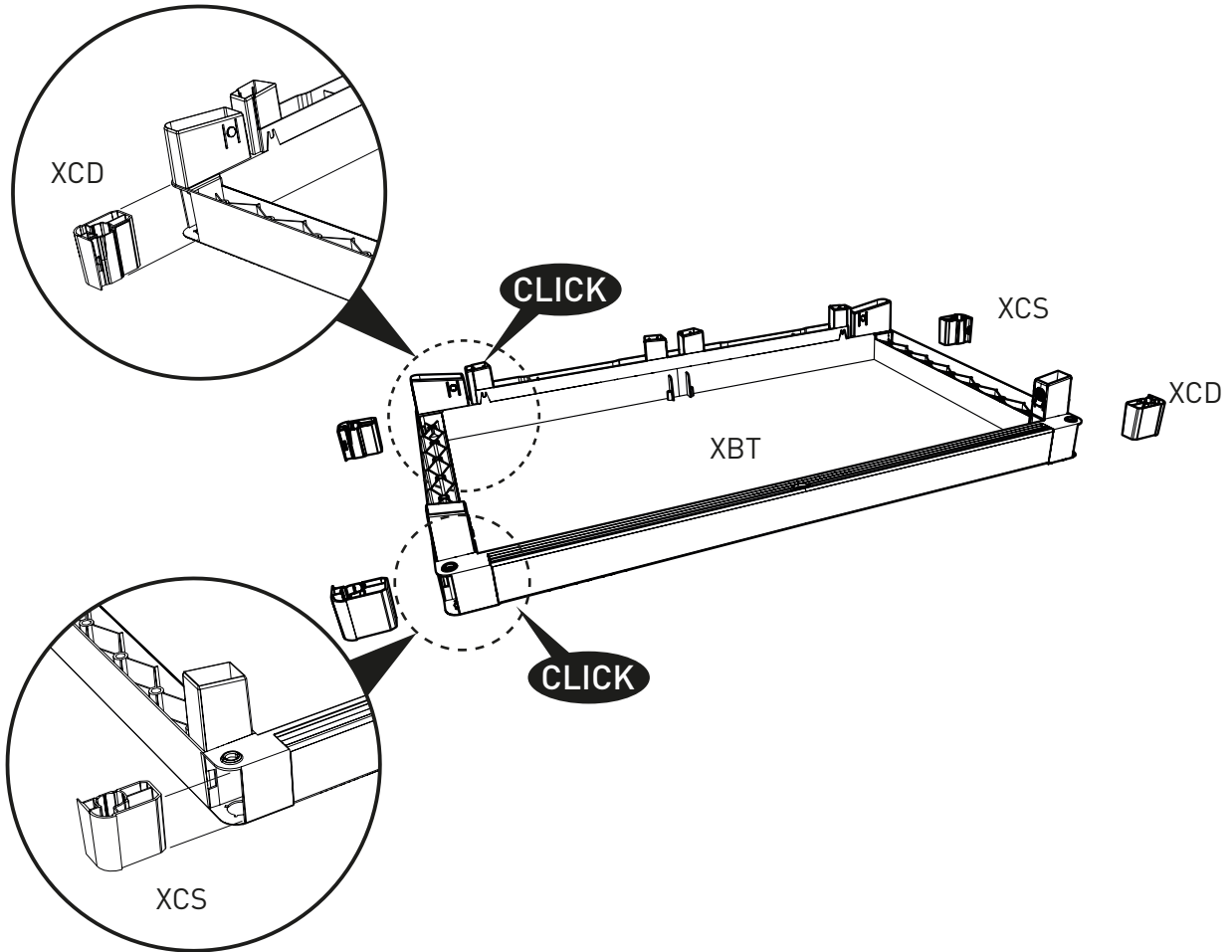

2

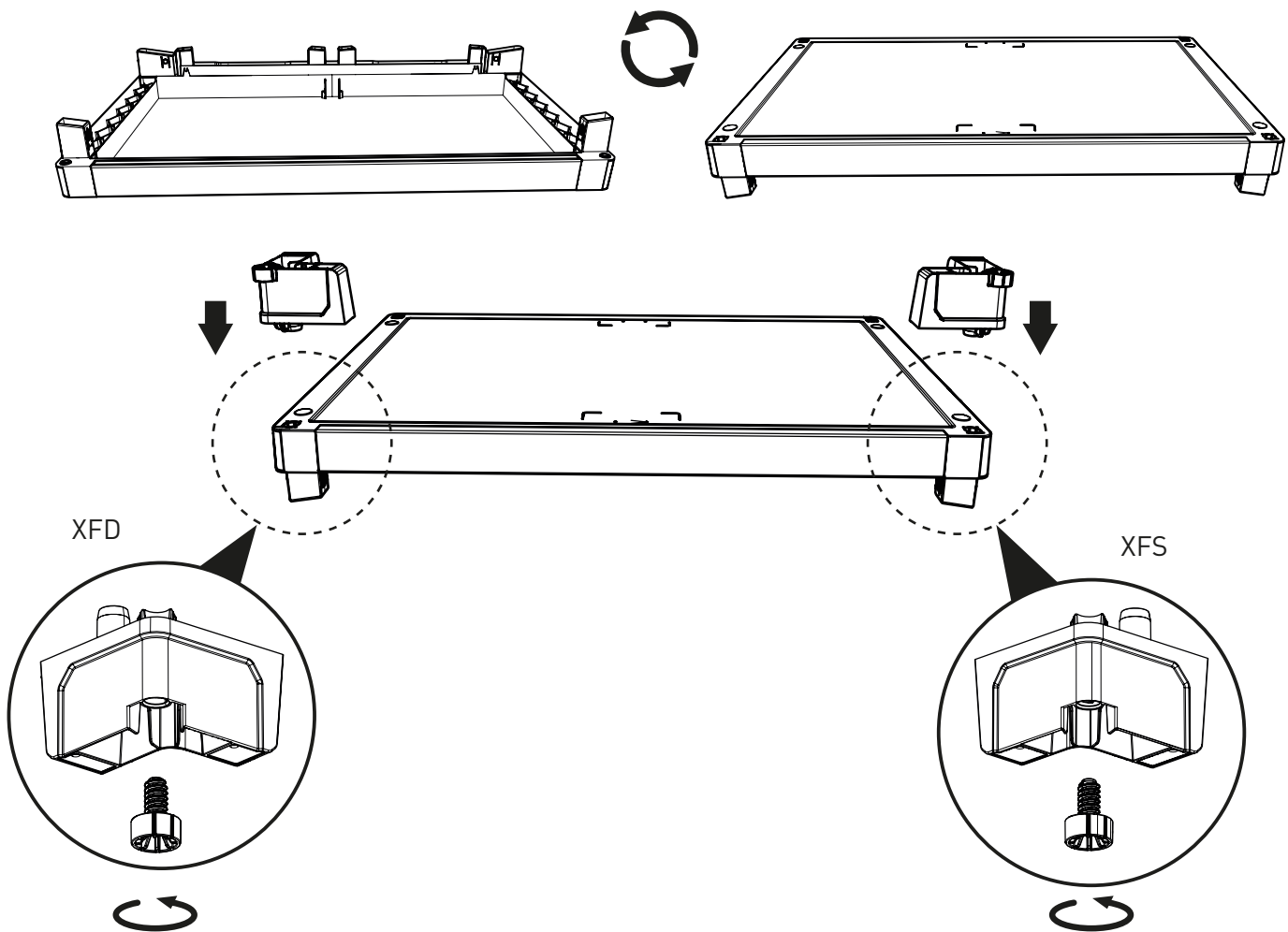

3

XFS

XFD

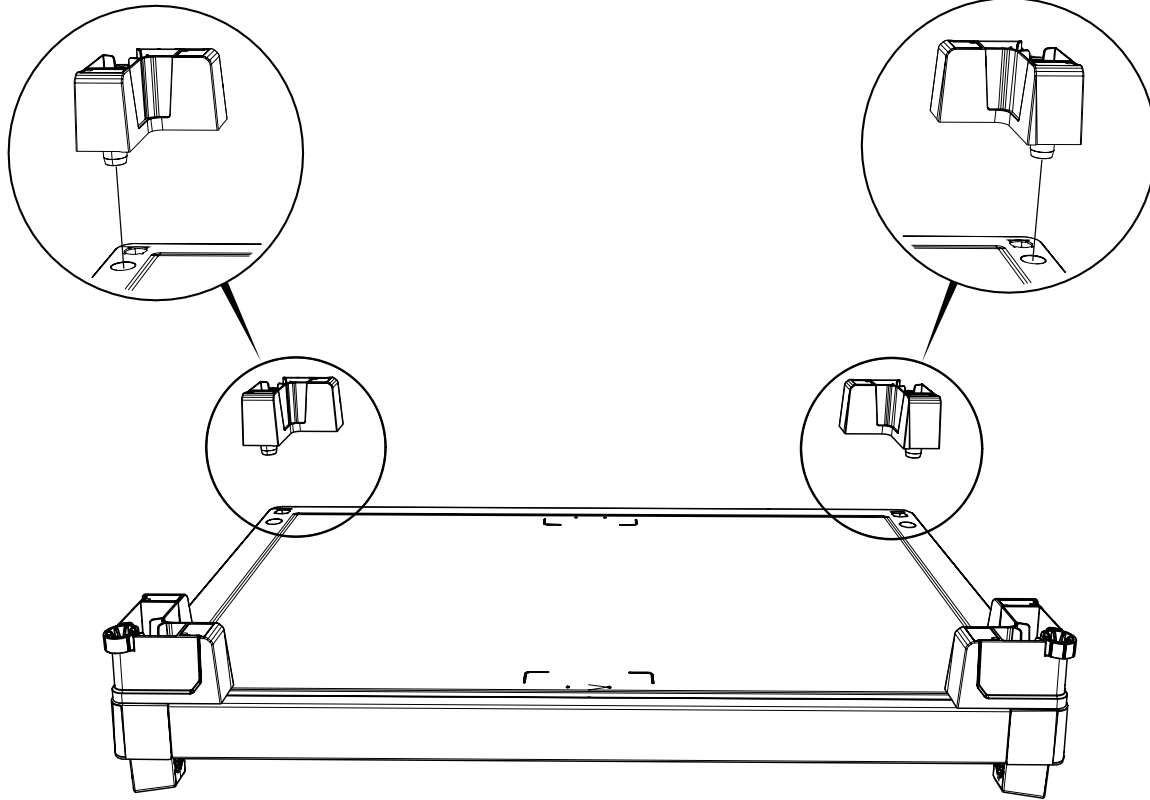

4

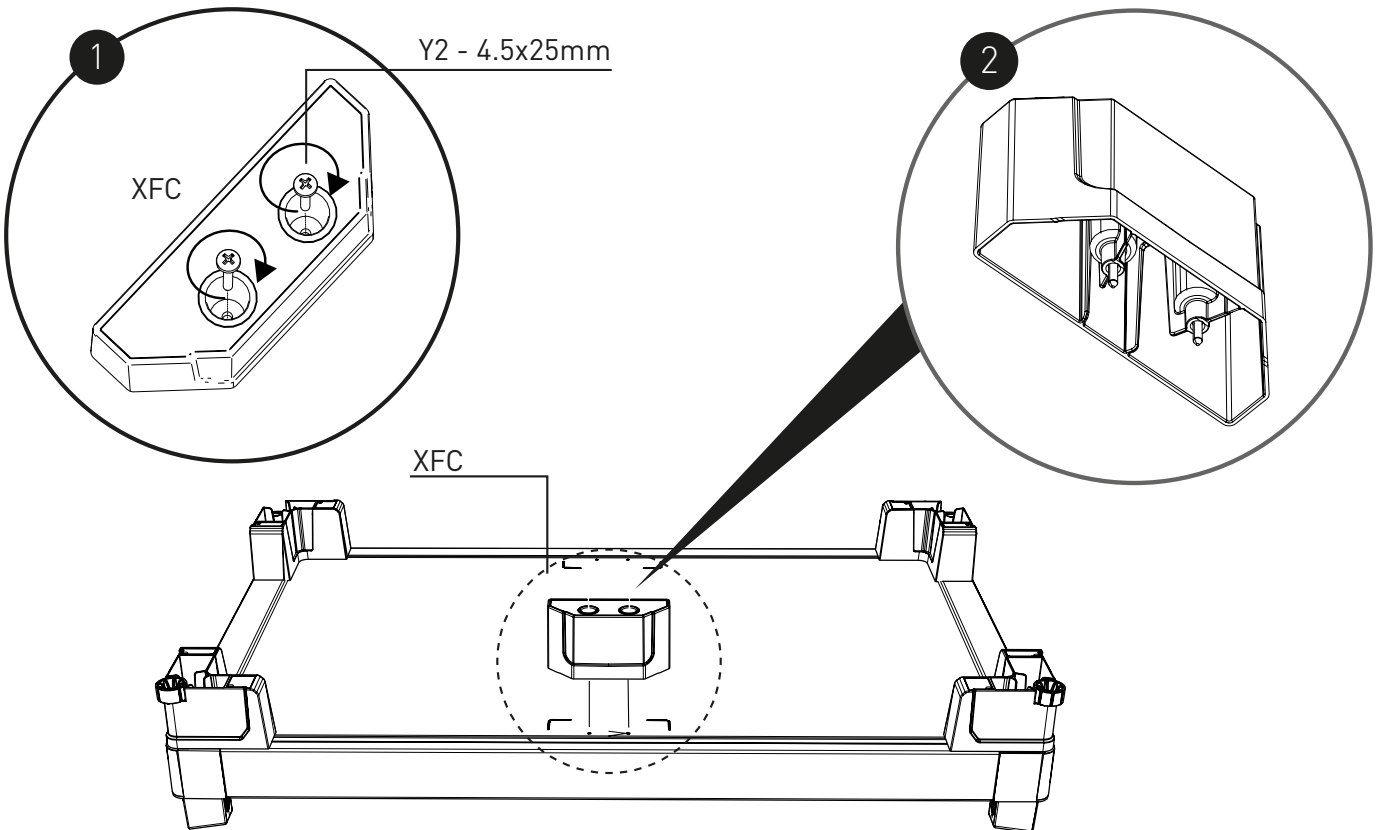

5

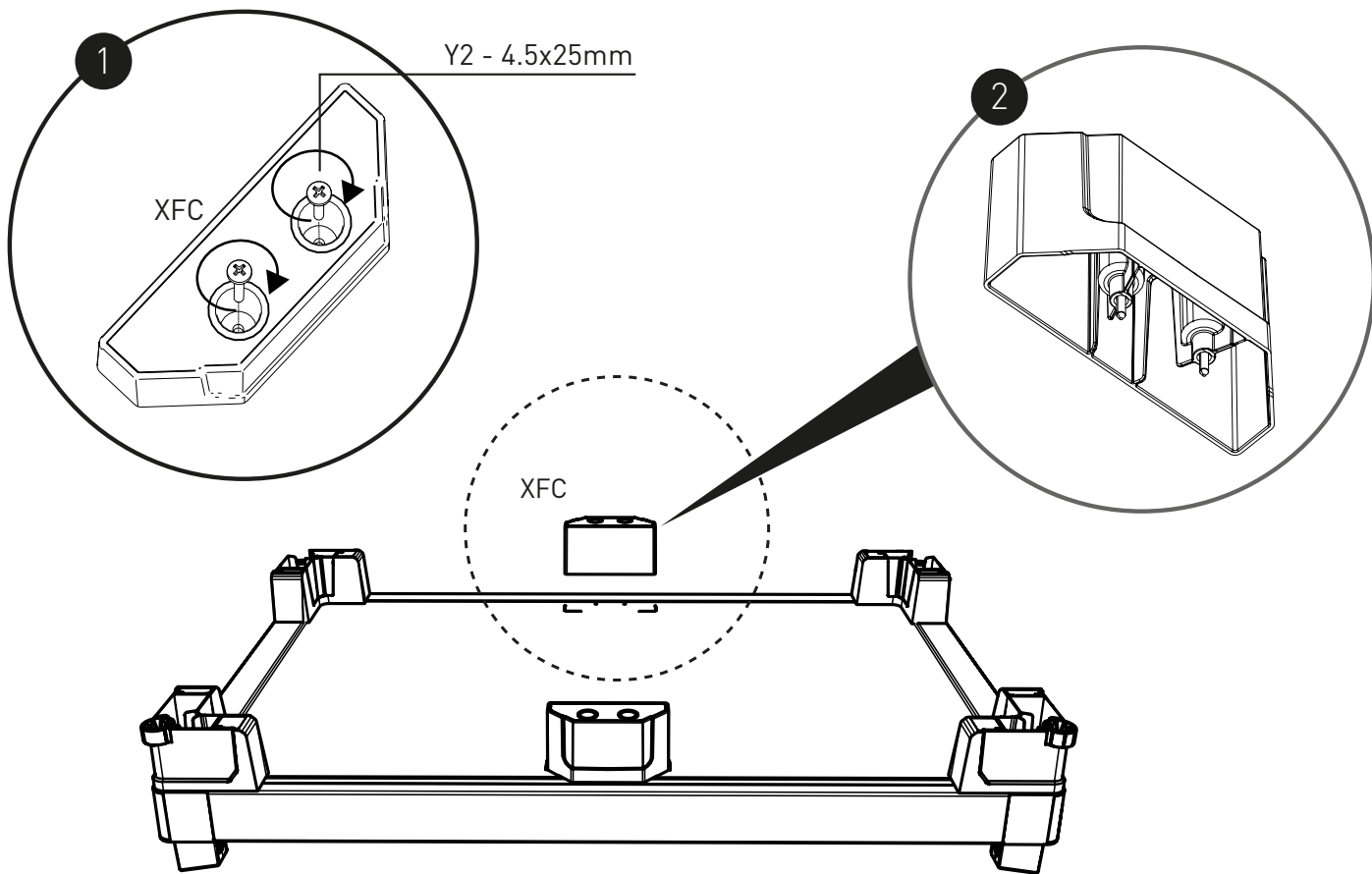

6

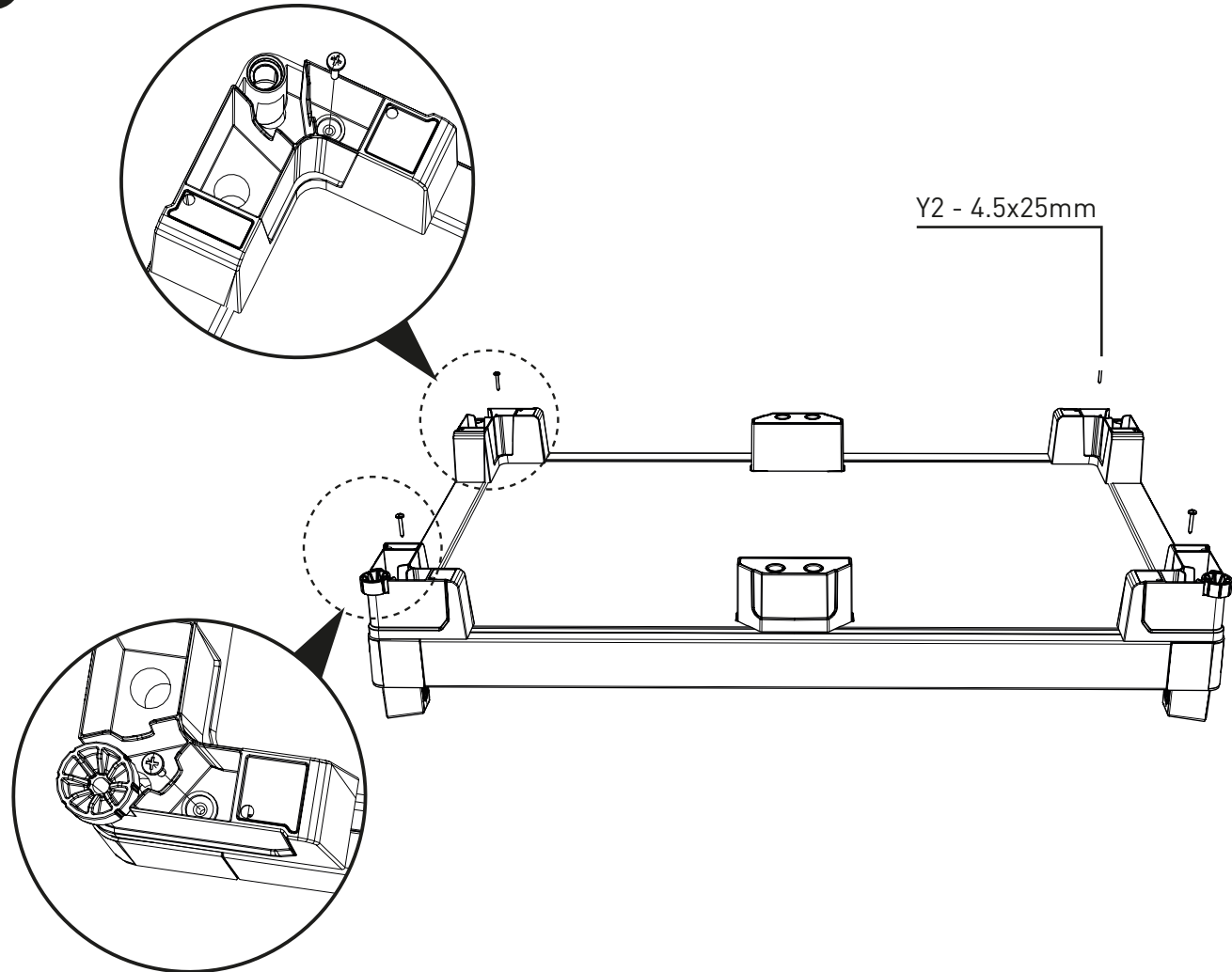

7

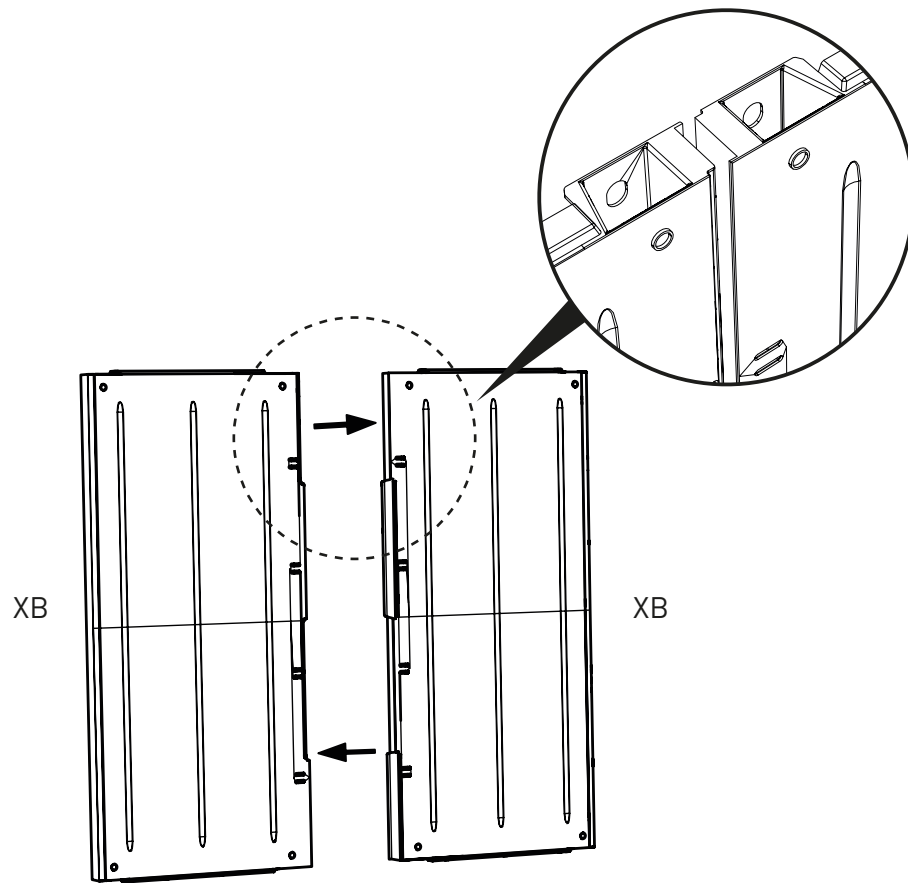

8

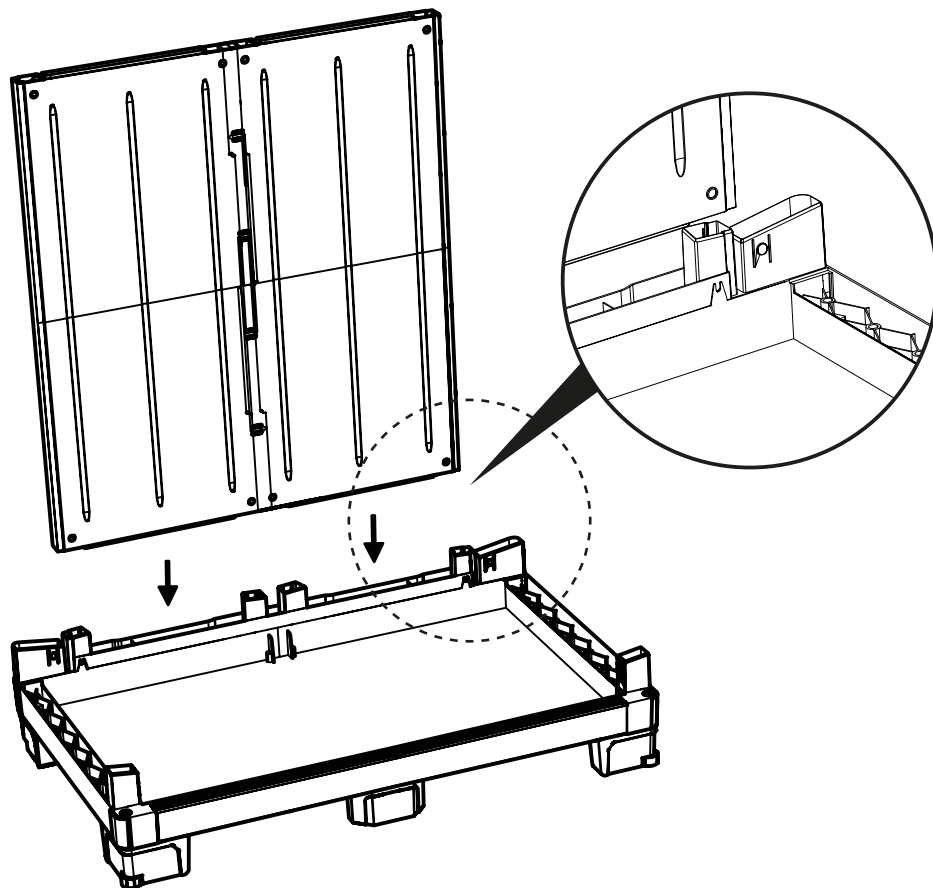

9

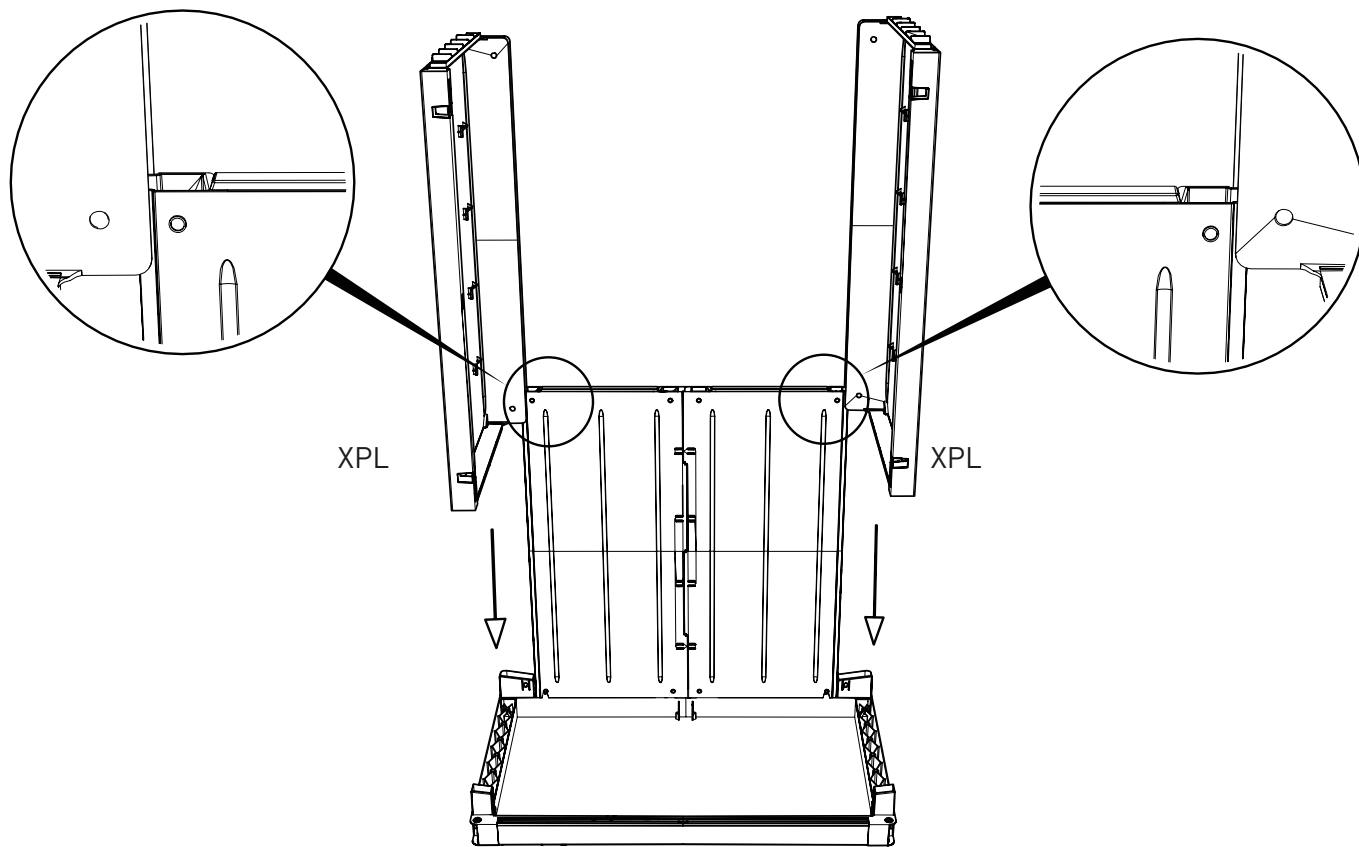

10

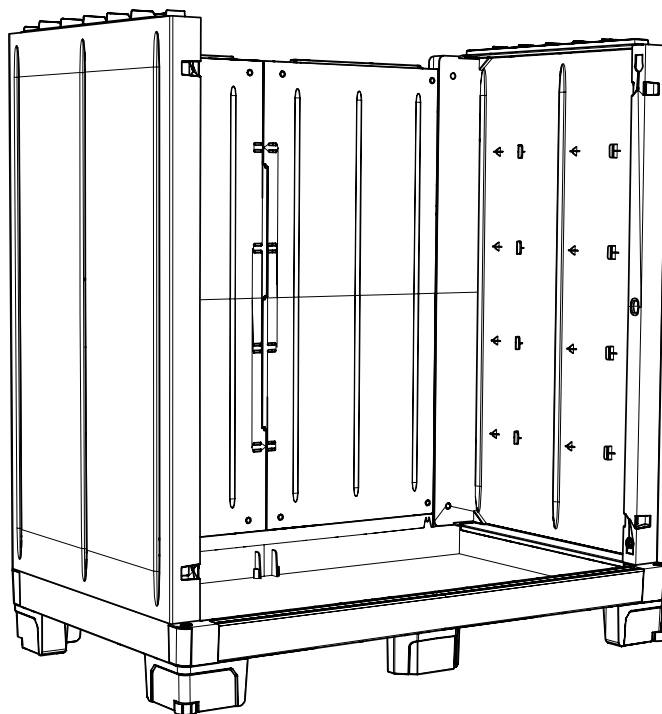

11

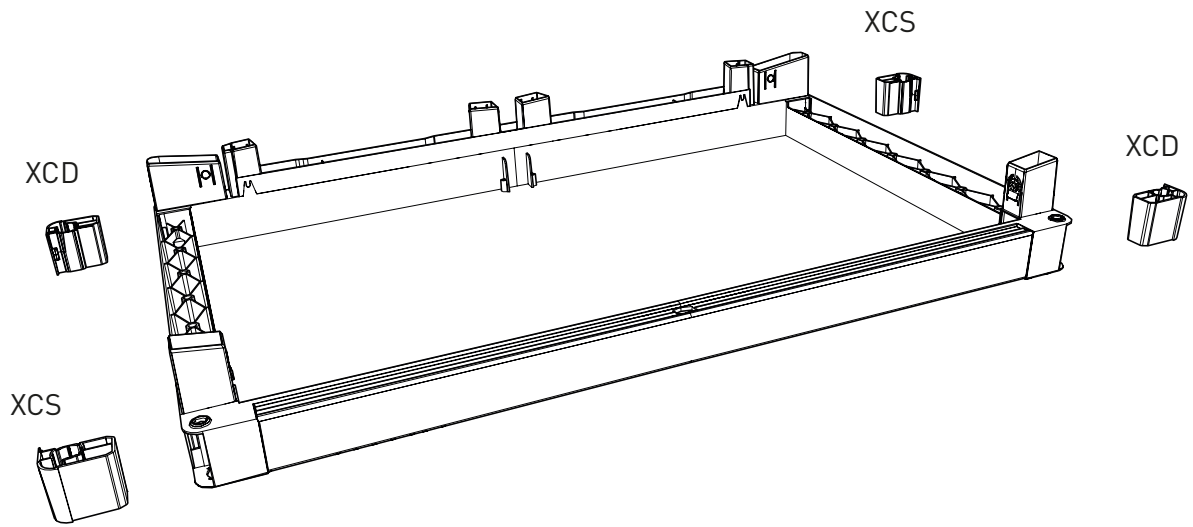

12

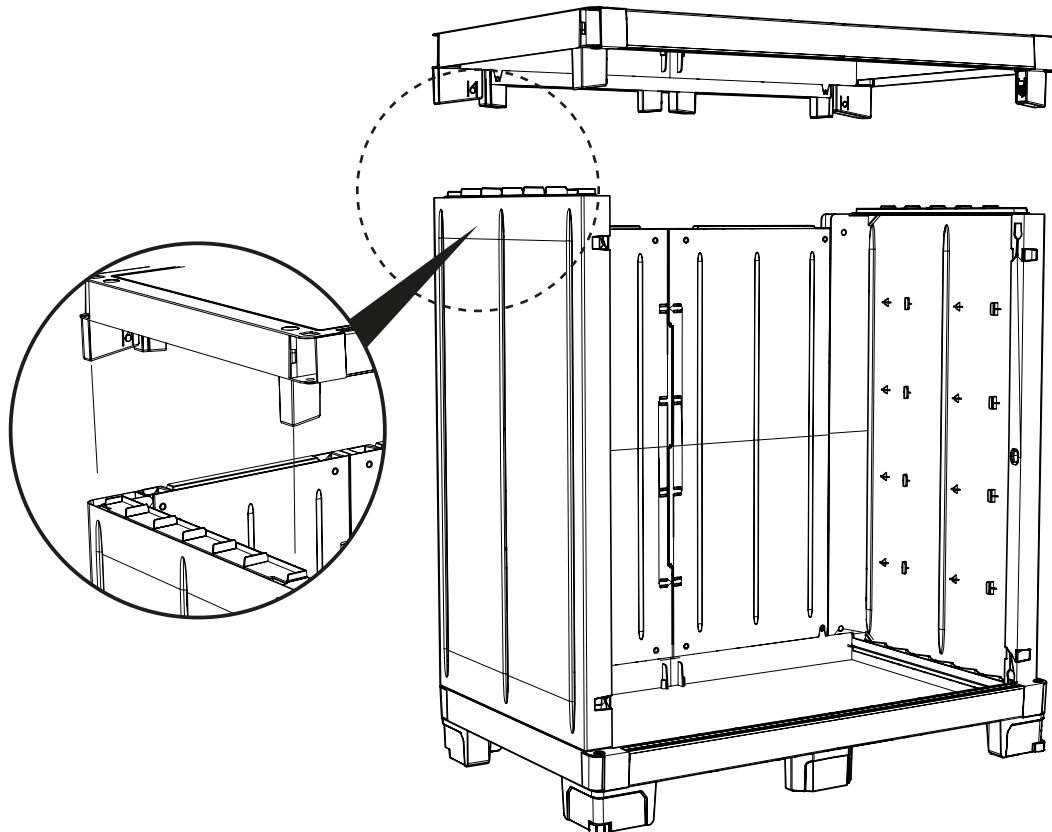

13

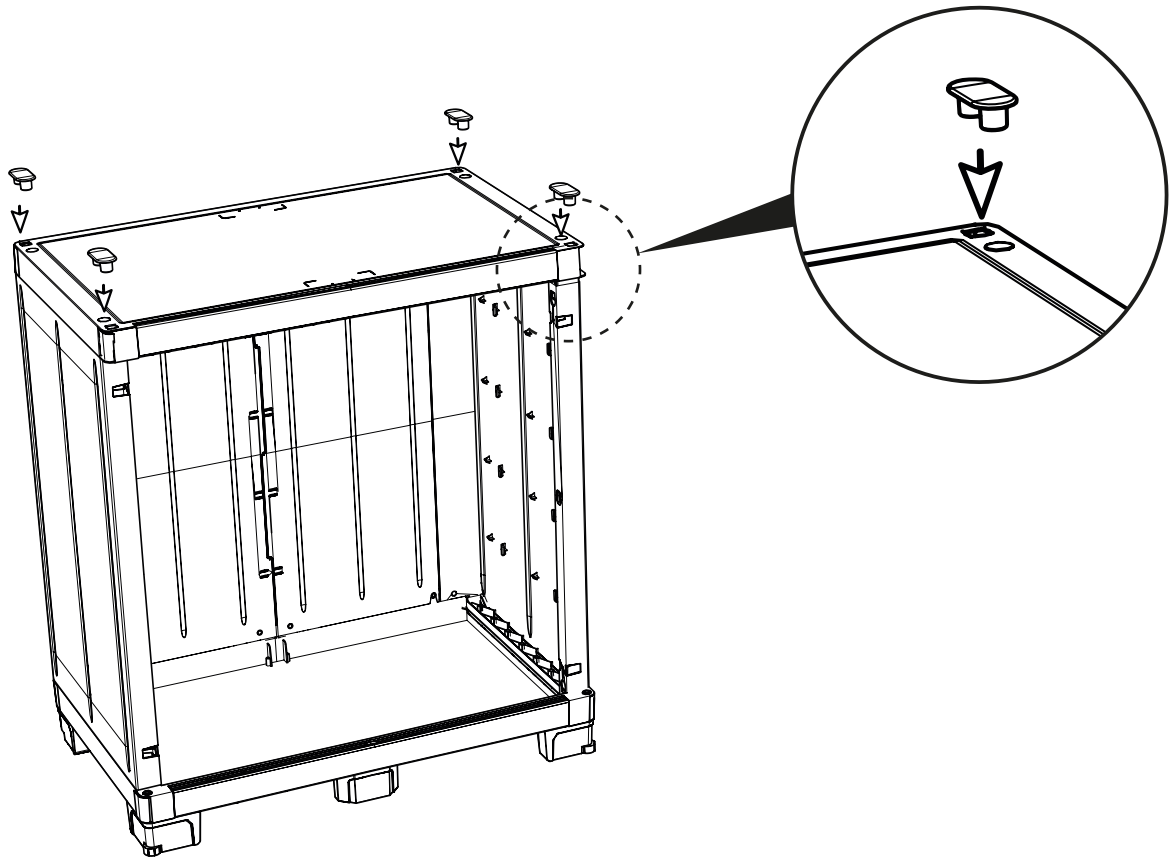

14

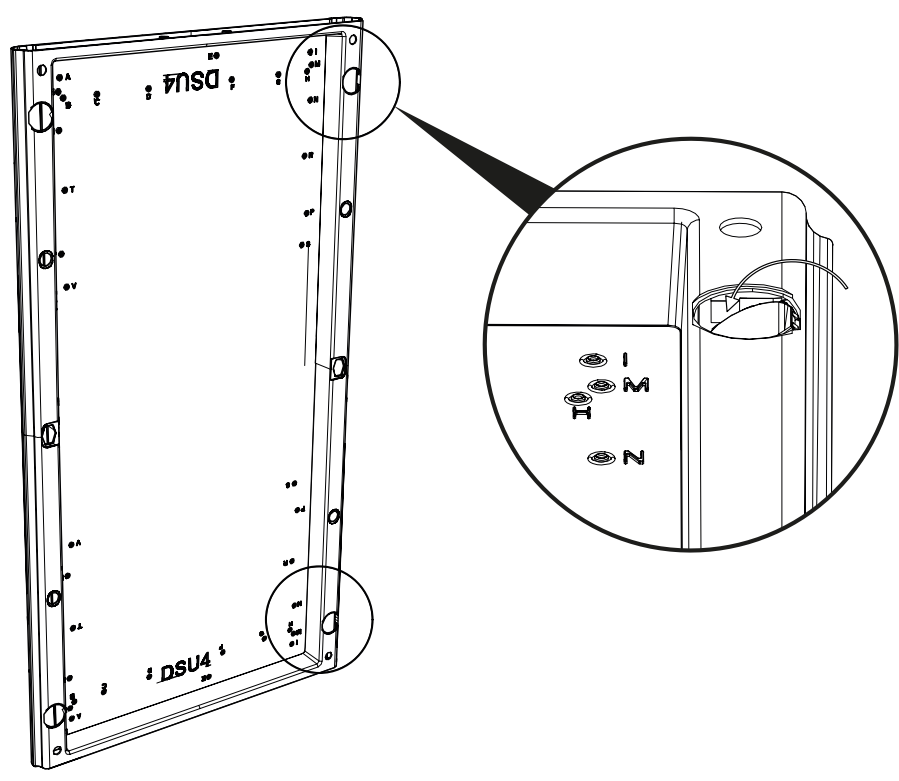

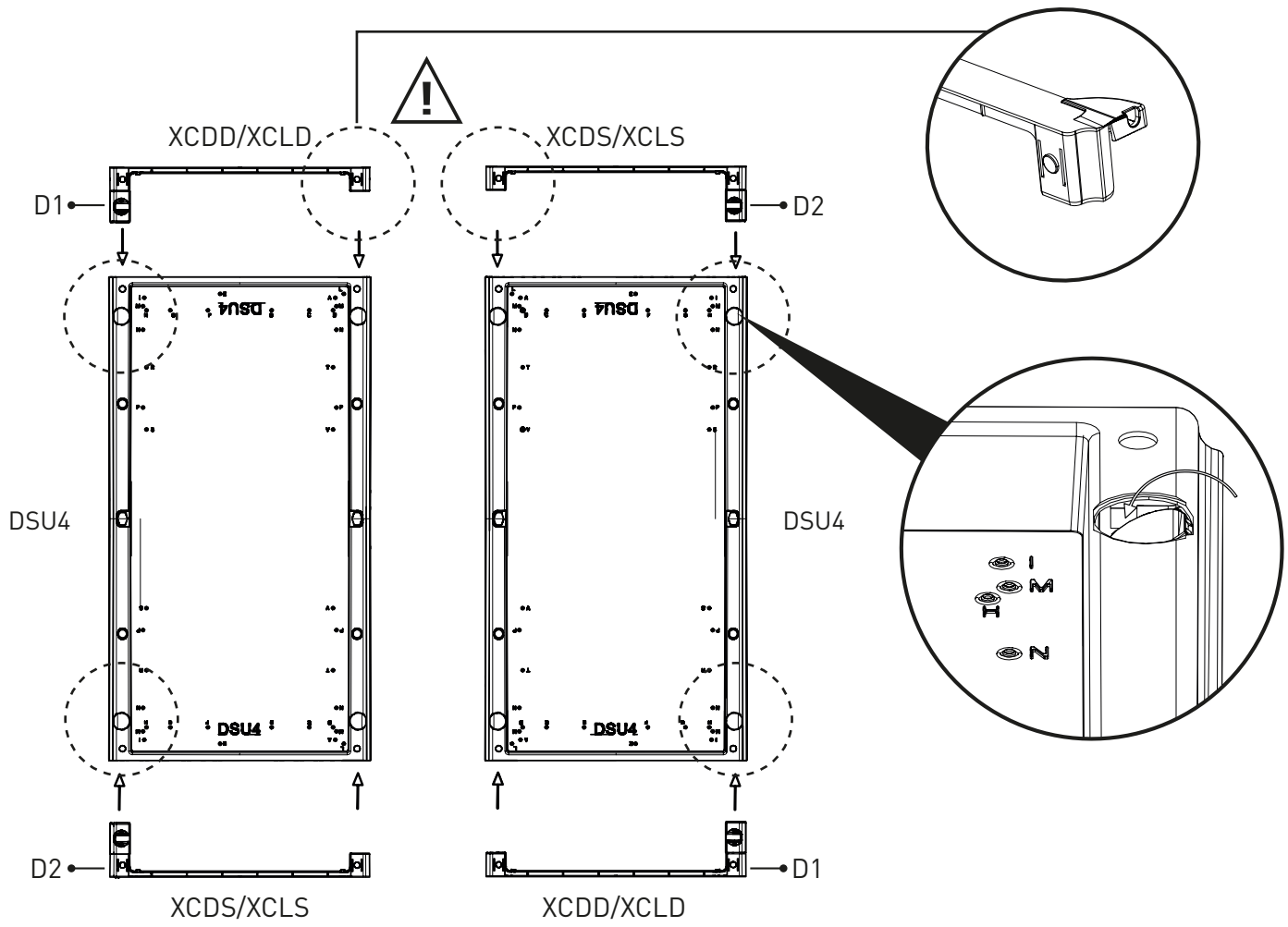
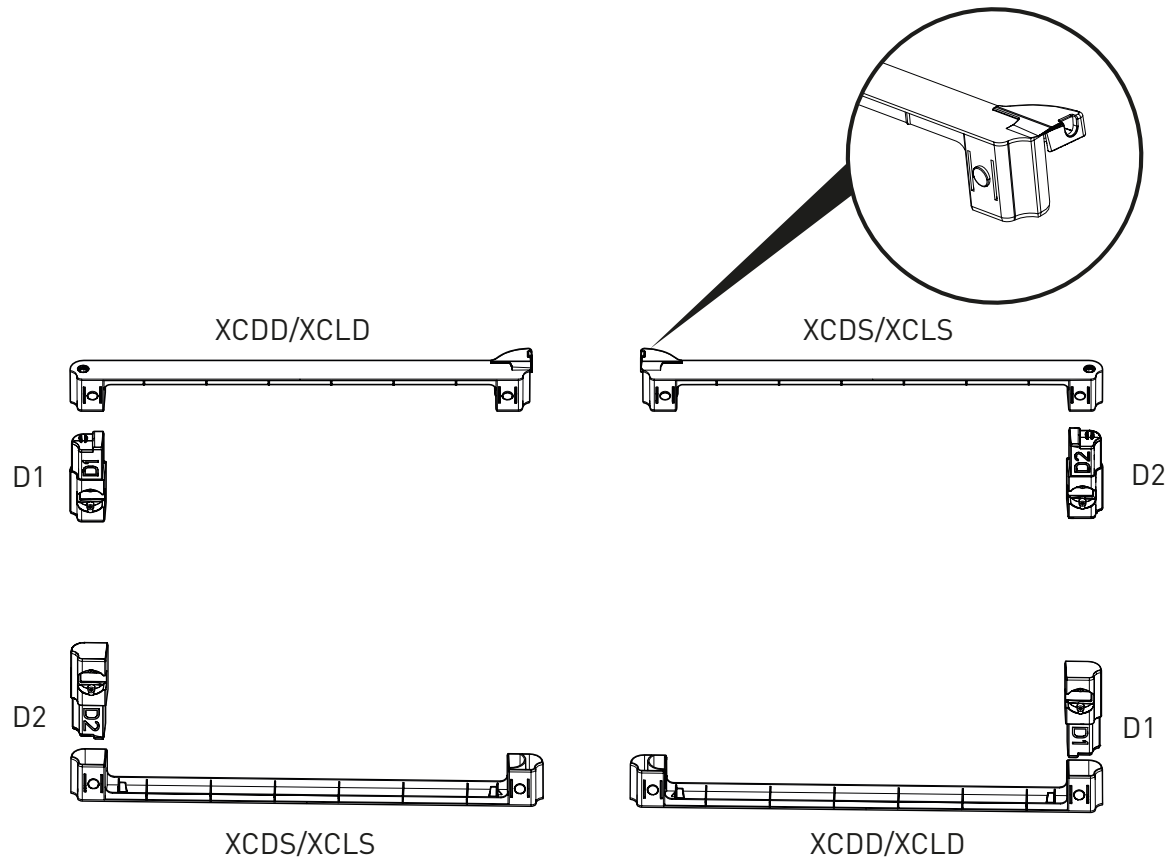

17

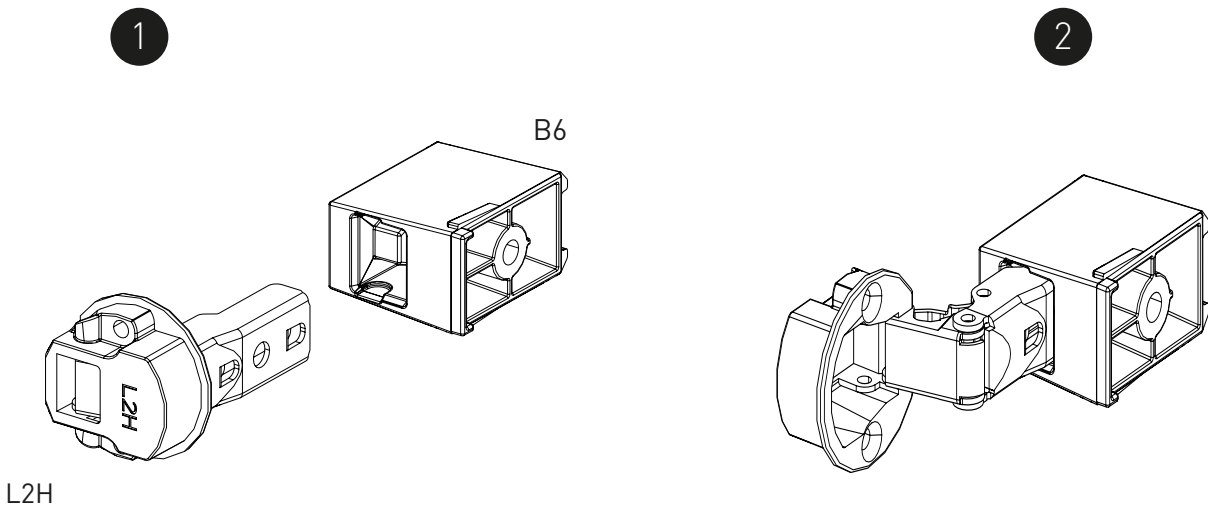

18

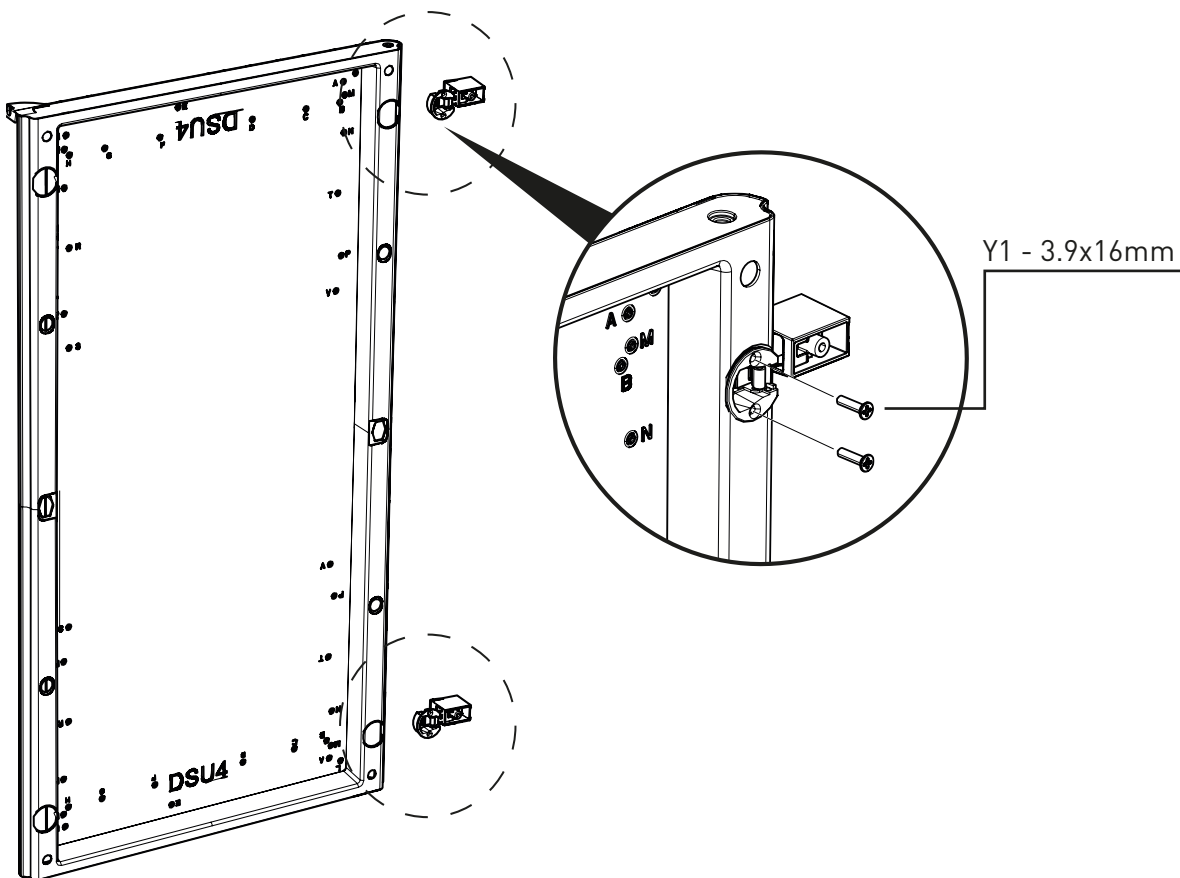

19

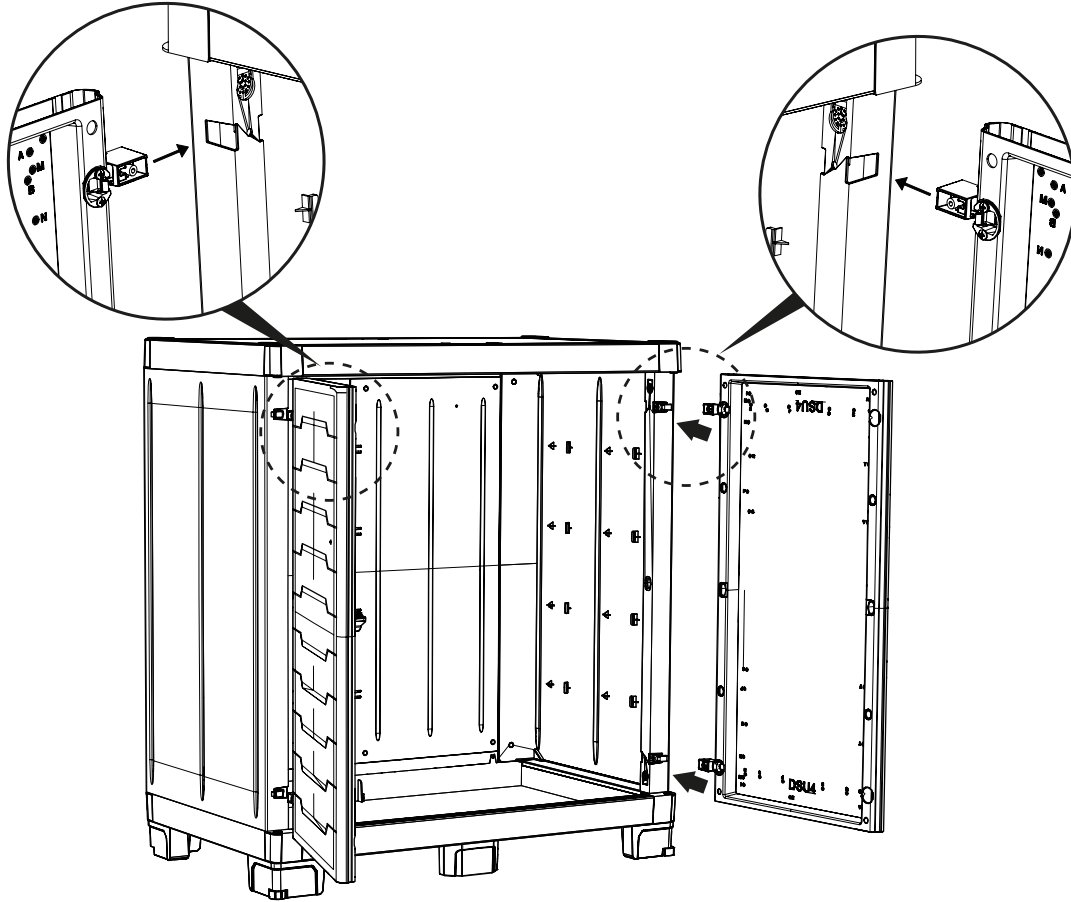

20

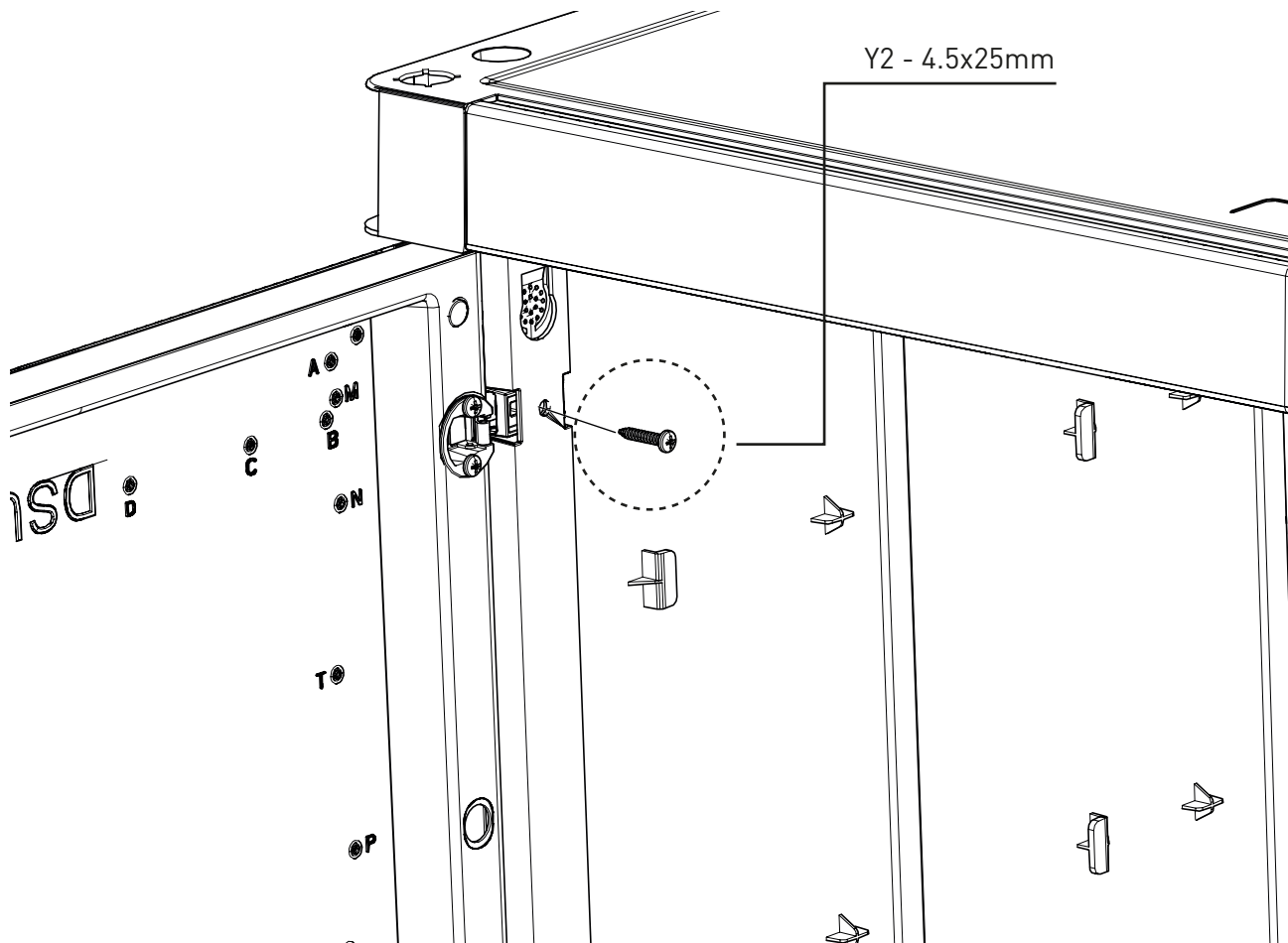

21

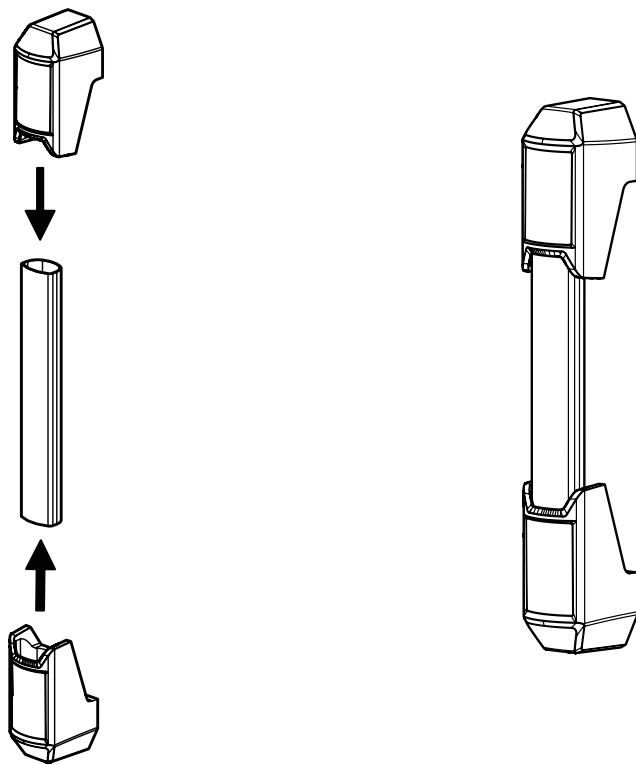

22

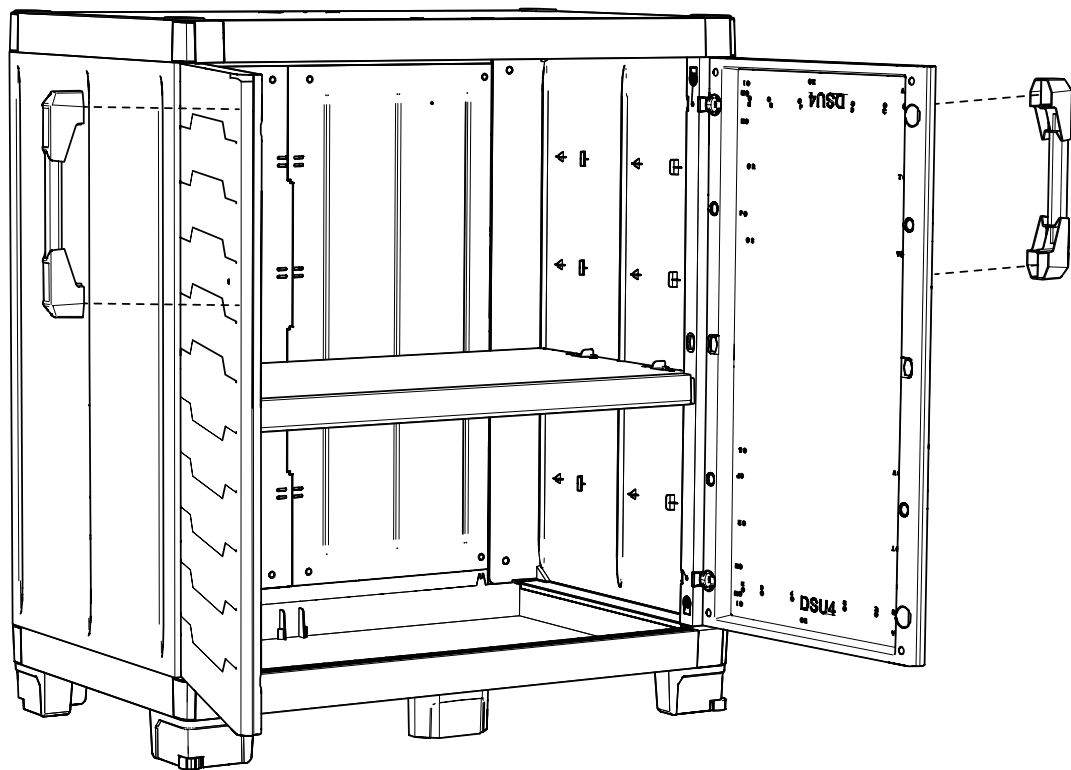

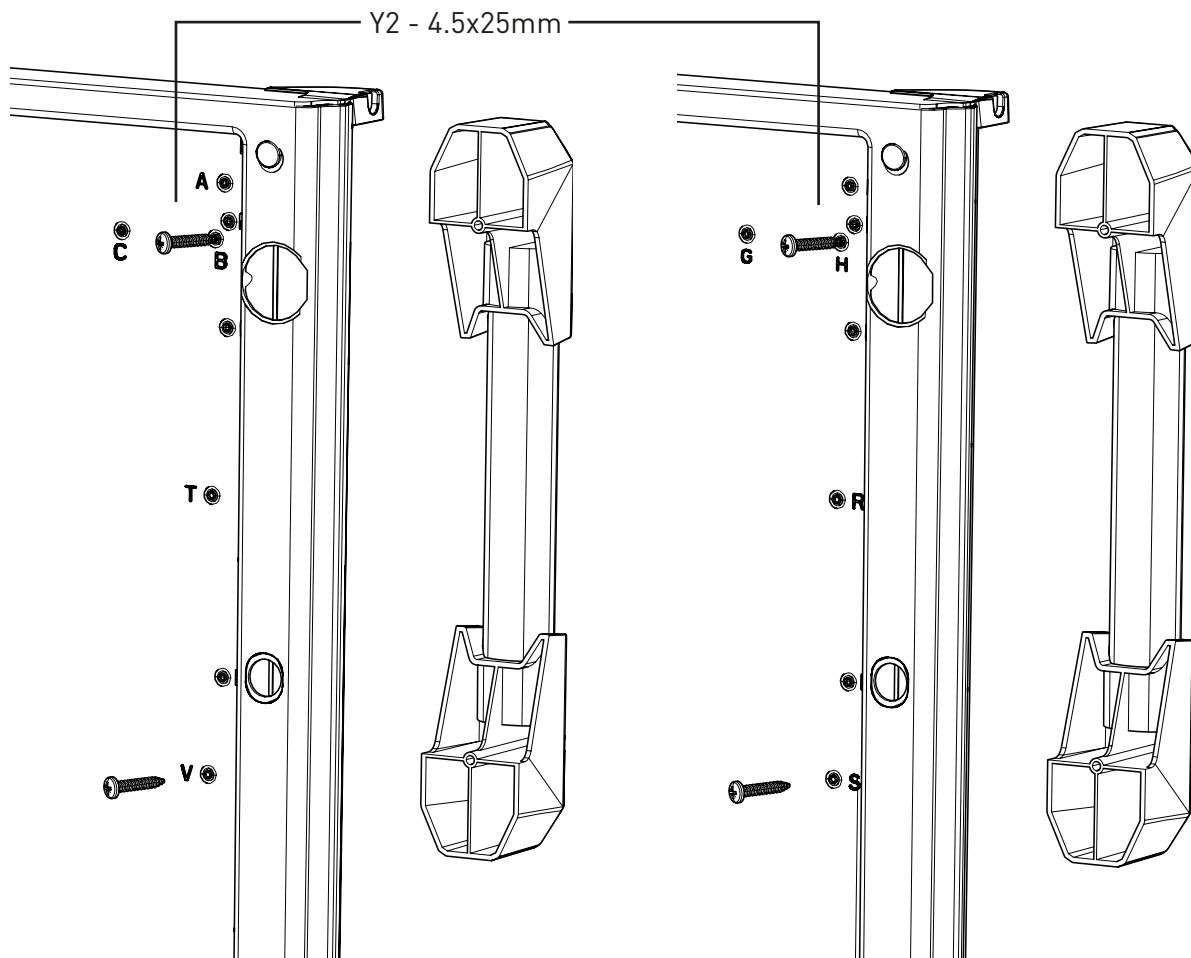

- To fix the handle to the door, insert the screws at the places marked "B/V" or "H/S".
- Pour fixer la poignée à la porte, sélectionnez la position « B/V » ou « H/S » et insérez la vis.
- Um den Griff an der Tür zu befestigen, wählen Sie die Position „B/V“ oder „H/S“ und setzen Sie die Schraube ein.
- Om de handgreep aan de deur te bevestigen, selecteert u de posities "B/V" of "H/S" en brengt u de schroef in.
- Para fijar la manija a la puerta, seleccione las posiciones «B/V» o «H/S» e inserte el tornillo.
- Per fissare le maniglie alla porta selezionate le posizioni «B/V» o «H/S» e inserite la vite.
- Para fixar o puxador na porta, seleccione as posições "B/V" ou "H/S" e introduza o parafuso.
- Για να στερεώσετε τη χειρολαβή στην πόρτα, επιλέξτε τις θέσεις «B/V» ή «H/S» και εισαγάγετε τη βίδα.
- Aby zamocować klamkę do drzwi, należy wybrać pozycje „B/V” lub „H/S” i wkręcić śrubę.
- 要将手柄安装在小门上，请选择“B/V”或“H/S”位置并拧入螺钉
- A fogantyú ajtóhoz való rögzítéséhez válassza ki a „B/V” vagy az „H/S” pozíciót, és csavarja be a csavart.
- Kako biste pričvrstili ručku na vrata, odaberite položaje "B/V" ili "H/S" i umetnite vijak.
- Pentru a fixa mânerul de ușă, selectați pozițiile „B/V” sau „H/S” și introduceți șurubul.
- Če želite ročico pritrditi na vrata, izberite položaj "B/V" ali "H/S" in vstavite vijak.
- За да фиксирате дръжката към вратата, изберете позиция "B/V" или "H/S", след което поставете винта
- Чтобы закрепить ручку на двери, выберите место, обозначенное «B/V» или «H/S» и вставьте винт
- Щоб зафіксувати ручку на дверях, виберіть положення "B/V" або "H/S" та вставте шуруп
- Chcete-li upevnit rukojeť ke dveřím, zvolte polohu "B/V" nebo "H/S" a zasuňte šroub
- Pre upevnenie kľučky na dvere, zadajte polohu "B/V" alebo "H/S" a vložte skrutku.
- Norėdami pritvirtinti rankeną prie durų, pasirinkite "B/V" arba "H/S" padėtį ir įkiškite varžtą
- Lai piestiprinātu durvju rokturi, izvēlieties pozīcijas "B/V" vai "H/S" un ievietojiet skrūvi
- Käepideme kinnitamiseks uksele valige "B/V" või "H/S" asendid ja sisestage kruvi

24

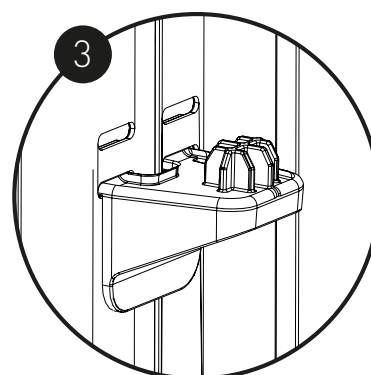
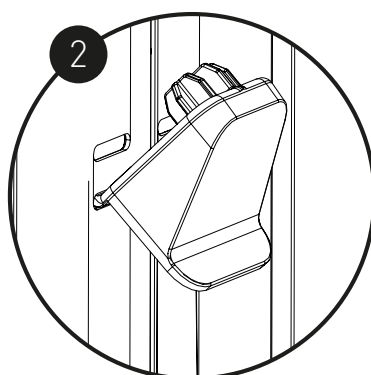
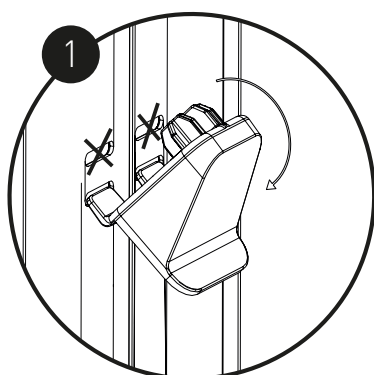
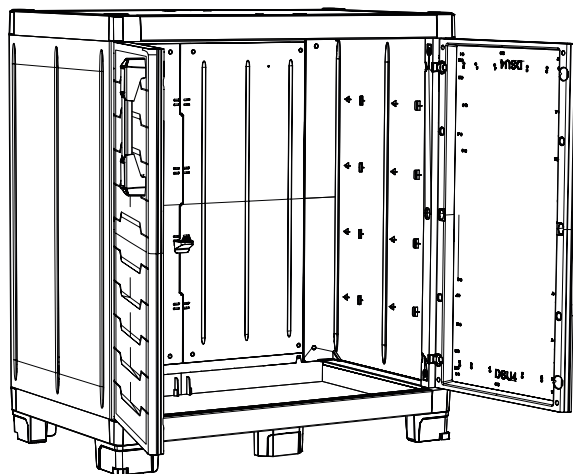

25

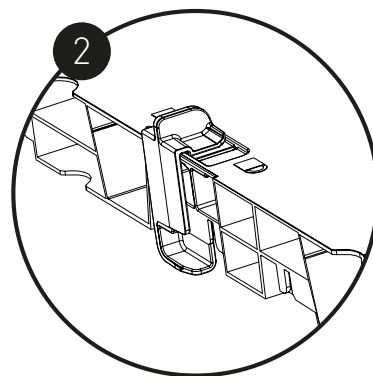
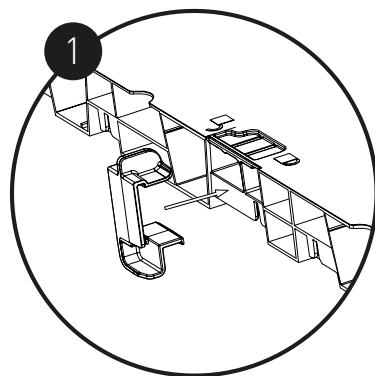

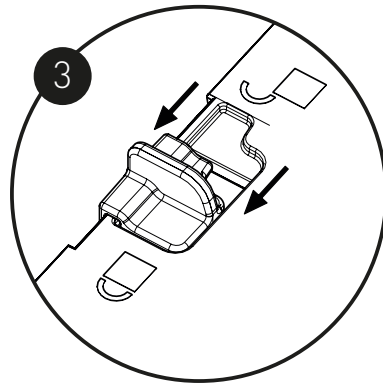
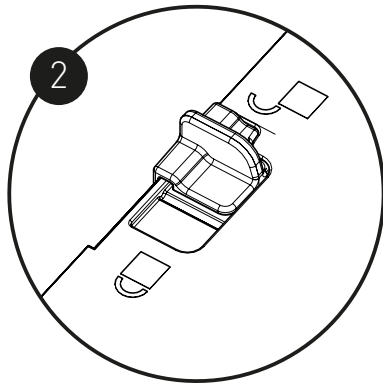
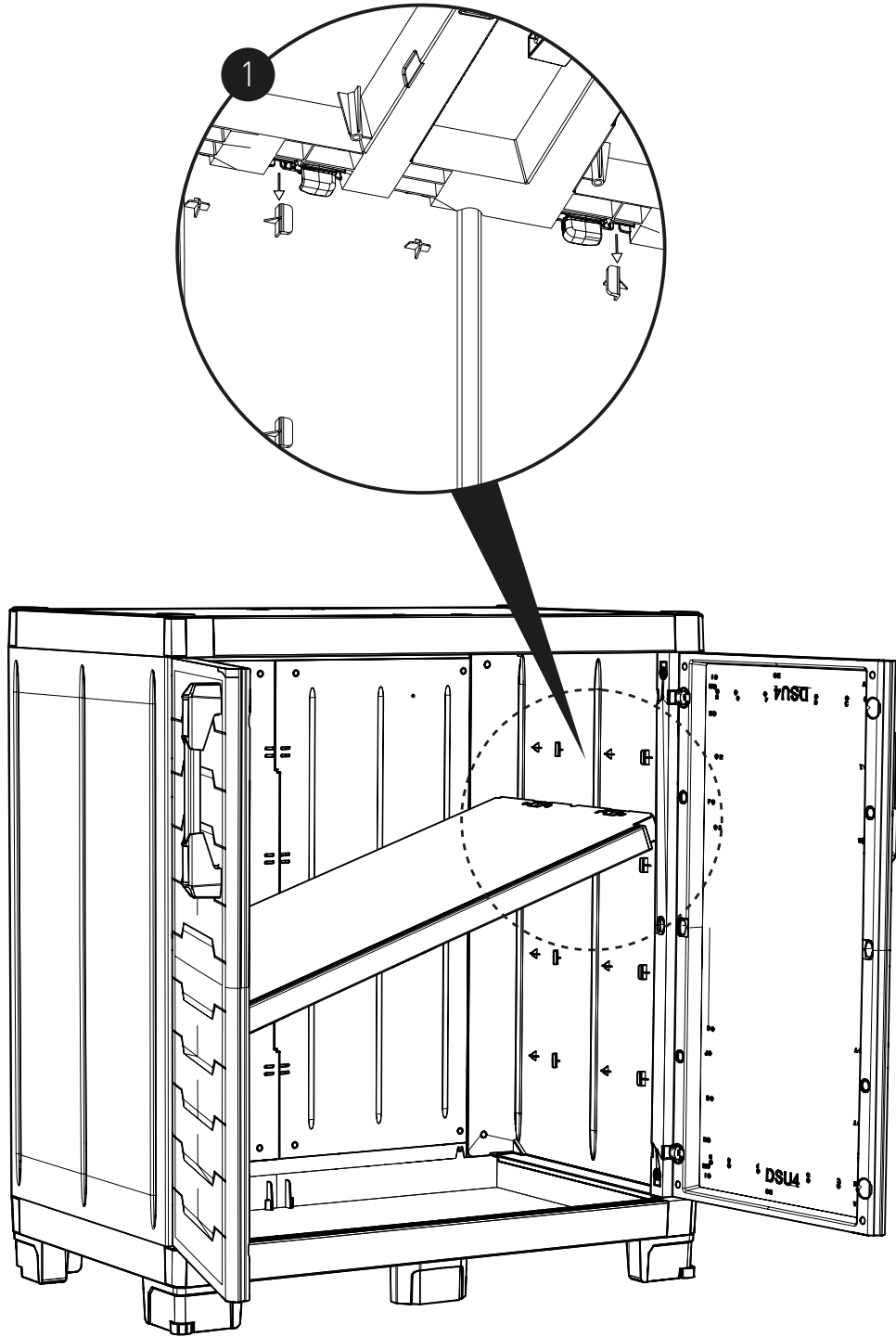

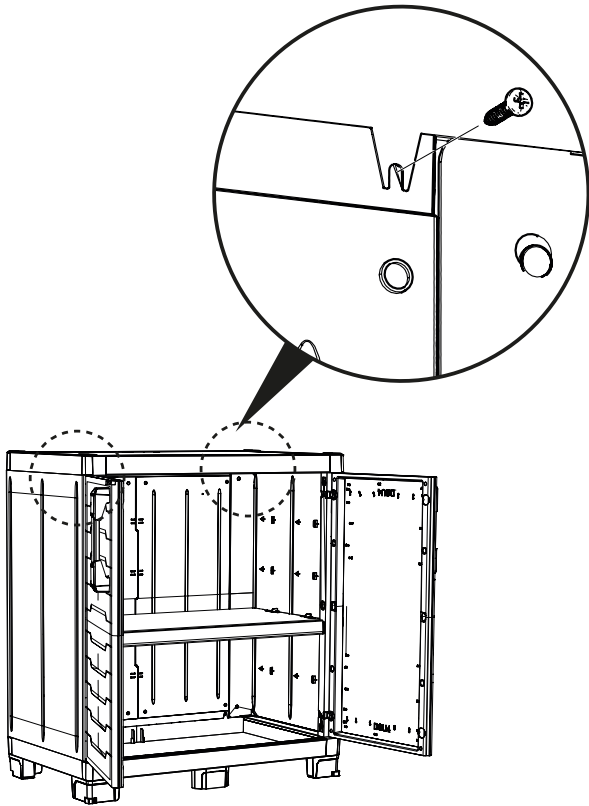

- Fasten the cupboard to the wall (screws and anchors not included). Choose the anchor according to the surface.
- Fije el armario en la pared (la dotación no incluye tornillos y tacos). Elija el taco en función de la superficie de apoyo.
- Fixe o armário na parede (parafusos e buchas não incluídos). Escolher a bucha conforme a superfície de apoio.
- Στερώστε την ντουλάπα στον τοίχο (βίδες και ούπα δεν περιλαμβάνονται). Επιλέξτε το ούπα ανάλογα με την επιφάνεια στήριξης.
- Fissare l'armadio a muro (viti e tasselli non inclusi). Scegliere il tassello in base alla superficie di appoggio.
- Bevestig de kast aan de muur (schroeven en pluggen niet bijgeleverd). Kies de plug aan de hand van het steunoppervlak.
- Fixer l'armoire au mur (vis et chevilles non incluses). Choisir la cheville en fonction de la surface d'appui.
- Befestigen Sie den Schrank an der Wand (Schrauben und Dübel sind nicht im Lieferumfang enthalten). Den Dübel je nach Stellfläche wählen.
- Przymocować szafę do muru (śruby i kotki nie są zawarte w dostawie). Dobrac kotek w zależności od powierzchni oparcia.
- 将橱柜固定在墙上（螺丝和锚固螺栓不属于供货范围）。根据表面选择锚固螺栓。
- A szekrény a falhoz rögzítendő (a csavarokat és a dübeleket a termék nem tartalmazza). A dübel a fal fajtajához válasszandó.
- Pričvrstite ormar na zid (vijci i košuljice nisu uključeni u isporuku). Odaberite košuljicu ovisno o površini oslonca.
- Fixați dulapul de zid (șuruburile și diblurile nu sunt incluse în set). Alegeți dublul în funcție de suprafața de sprijin.
- Pritrditi omaro na zid (vijaki in zatiči niso priloženi). Zatič je treba izbrati upoštevaje površino zida.
- Прикрепете шкафа към стената (доставката не включва винтове и дюбели). Изберете дюбеля в зависимост от опорната повърхност.
- Прикрепить шкаф к стене (болты и дюбели не входят в комплект). Подобрать дюбель в зависимости от опорной поверхности.
- Прикріпити шафу до стіни (гвинти та дюбелі не входять у комплект). Підібрати дюбеля відповідно до поверхні кріплення.
- Skříň připevněte na stěnu (šrouby a hmoždinky nejsou v balení). Hmoždinku vyberte podle povrchu připevnění.
- Skriņu piņevnīte k stene (skrūtķy a rozperķy nie sū v sūprave). Rozperņķ kolīķ vyberte nāleķzīte podķla tķpu daneķ steny.
- Spīņķ prīvērtīntī pīe sienos (varķķtai ir ķaiķķķai nejēina ķ tiekīmo apīmķķ). Pasīrīķntī atrāmīnīam pavīrķīu tīnkamā ķaiķķķ.
- Skapi piestīpīnāt pīe sienas (skrūves un dībeļķ neietīlpst pīegādes ķomplektā). Dībeļķ jāīzvēlas atbīlstoķī atbalsta vīrsmai.
- Kinnitada kapp mūīrīle (kruvīd ja tūūblīd ķomplekti ei kuulu). Valīda tūūblīd tūgīpnīnast sōltuvalt.

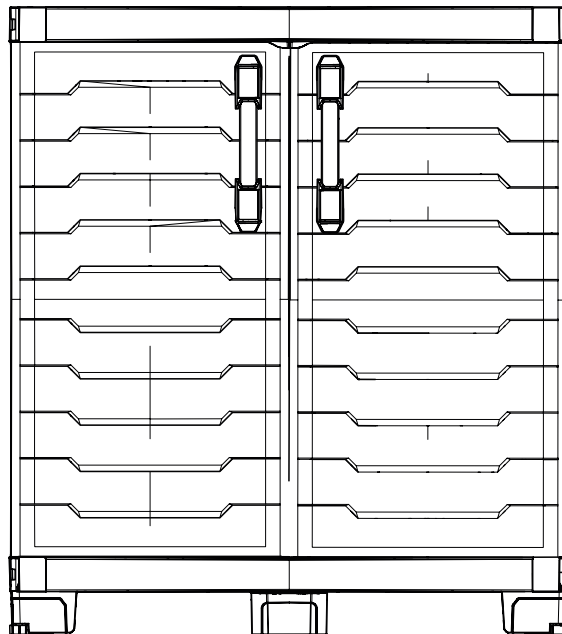



After assembly is completed there may be extra small parts, you may dispose of these as they are not needed | Une fois l'assemblage terminé, il se peut que vous ayez quelques petites pièces en trop dont vous pouvez vous débarrasser car elles ne sont pas nécessaires | Soliten nach dem Zusammenbau kleinere Plastikteile übrig geblieben sein, so können Sie diese entsorgen | Finalizado el montaje, pueden sobrar algunas piezas, puede disponer de ellas pues no son necesarias | A montaggio ultimato possono avanzare alcune piccole parti, queste possono essere smaltite perchè non sono necessarie | Voor de zekerheid zijn extra kleine onderdelen toegevoegd, de onderdelen die teveel zijn ontvangen mag u weggevoeren bij uw huisafval | Concluído a assembleia, eles podem ter alguns pedaços mais que suficiente, pode os ter porque eles não são necessários | Po zakończeniu montażu mogą pozostać niewykorzystane drobne części, które można zutylizować | 装配完毕后, 可能会有额外的小零件, 可按要求处置, 因为不再需要这些零件。 | Az összeszerelés befejezését követően néhány apró rész megmaradhat. Ezeket megsemmisítheti, mert nincs rájuk szükség | Nakon završene montaže može preostati višak pojedinih malih dijelova, možete ih odložiti jer više nisu potrebni | După finalizarea asamblării, unele componente mici pot avansa, acestea putând fi eliminate, deoarece nu sunt necesare | Po montaži lahko ostajajo nekateri majhni deli, te je mogoče odstraniti, ker niso potrebni | След приключване на монтажа може да останат някои малки части, те може да бъдат изхвърлени, тъй като не са необходими | После установки могут остаться некоторые мелкие детали, их можно утилизировать, поскольку они не нужны | Після складання може статися так, що залишаться деякі невеликі деталі, їх можна утилізувати, оскільки вони не є необхідними | Je možné, že po montáži zbudou některé menší části, které mohou být zlikvidovány, jelikož již nejsou potřebné | Po kompletnej montáži môžu zvýšiť niektoré malé súčiastky, tieto môžu byť odstránené, pretože nie sú potrebné | Sumontavus, gali likti kelios nedidelės dalys, kurios gali būti išmestamos, nes nėra reikalingos | Pēc montāžas pabeigšanas dažas nelielas detaļas var palikt pāri, tās var izmest atkritumos, jo tās nav vajadzīgas | Pärast kokkupanekut võivad osad väikesed detailid edasi liikuda, need võib eemaldada, kuna need pole vajalikud | Όταν η συναρμολόγηση έχει ολοκληρωθεί μπορεί να υπάρχουν επιπλέον μικρά κομμάτια που δεν χρειάζονται, μπορείτε να τα διαθέσετε στα άχρηστα





